

ROUND GRIP pressure vessel CLAMPS

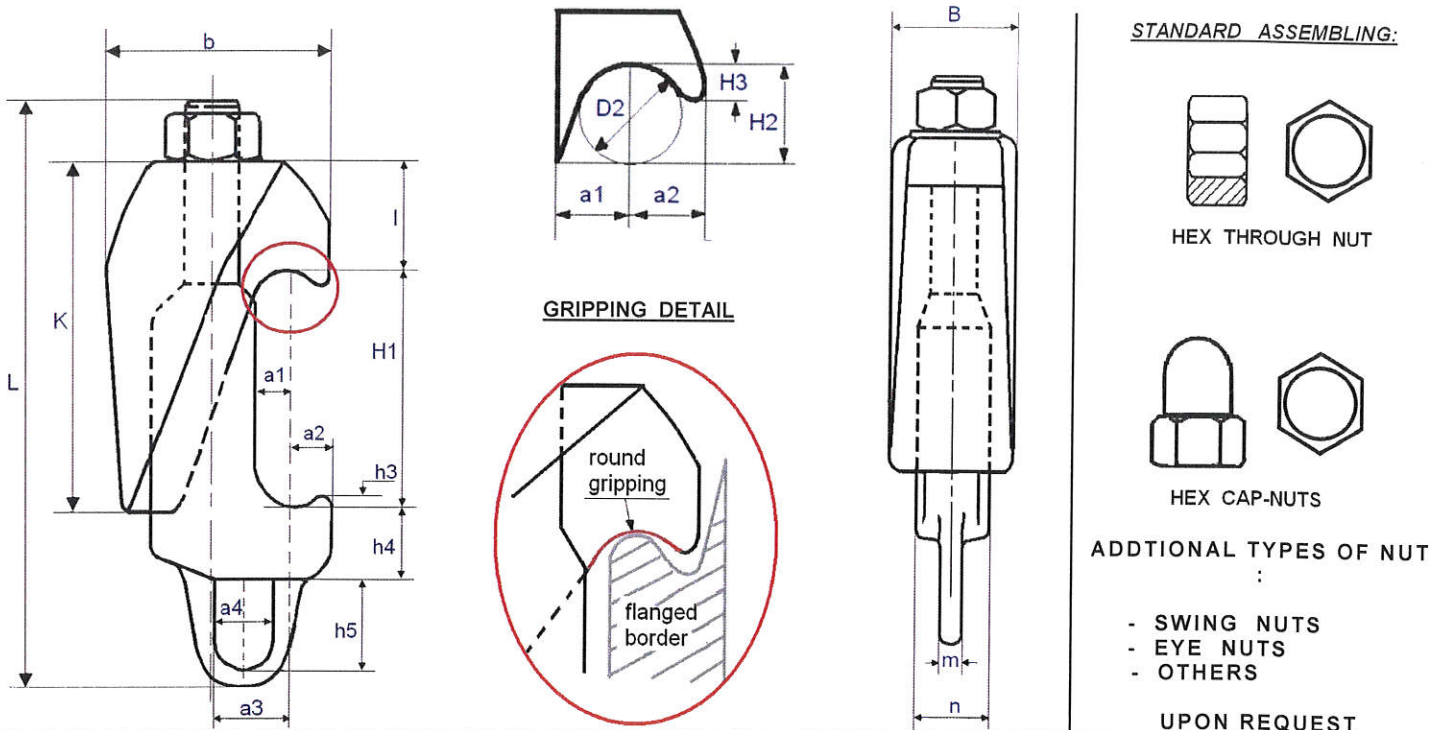

DIMENSIONS to DIN 28152

Standard size modification: upon request

TYPE	H1	L	B	H2 max	H3 max	D2 min.	a1 min.	a2 max	a3 min.	a4 min.	h4 max	h5 min.	K	b	l	m	n	Kg.	
	OPENING																		
M16	50 - 75	180	45	17	5	16	11	12	22	20	20	33	86	62	24	10	27	1,40	
M16	95 - 120	225	45	17	5	16	11	12	22	20	20	33	86	62	24	10	27	1,50	
M20	60 - 85	195	50	20	5	16	12	12	22	20	22	33	95	69	24	10	30	1,80	
M20	95 - 120	235	50	20	5	16	12	11	22	20	22	33	95	69	24	10	30	2,50	
M24	75 - 100	217	54	20	6	20	14	14	30	20	25	30	112	74	26	10	35	2,61	
M24	90 - 115	233	54	20	6	20	14	14	30	20	25	30	112	74	26	10	35	2,71	
M24	110 - 135	252	54	20	6	20	14	14	30	20	25	30	112	74	26	10	35	3,00	
M24	150 - 185	303	54	20	6	20	14	14	30	20	25	30	112	74	26	10	35	3,20	
M27	85 - 120	288	60	13	6	24	14	15	40	24	40	40	155	90	38	8	42	5,00	
M27	120 - 155	323	60	13	6	24	14	15	40	24	40	40	155	90	38	8	42	5,30	
M27	155 - 190	357	60	13	6	24	14	15	40	24	40	40	155	90	38	8	42	5,50	
M30	85 - 120	288	60	13	6	24	14	17	40	24	40	40	155	90	38	8	42	5,40	
M30	120 - 155	323	60	13	6	24	14	17	40	24	40	40	155	90	38	8	42	5,70	
M30	155 - 190	357	60	13	6	24	14	17	40	24	40	40	155	90	38	8	42	5,90	
M33	120 - 160	375	70	15	6	24	16	15	42	24	56	50	200	100	50	20	70	8,80	
M33	180 - 220	440	70	15	6	24	16	15	42	24	56	50	200	100	50	20	70	10,2	

Sizes in millimetres

- MATERIALS** : - 25CrMo4 (1.7218) to DIN EN 10269
 - AISI 316L / ASTM A193 Gr.B8M/ ASTM A182 F316L
 - production in other material: upon request
- FINISHING** : - yellow/ white zinc plating
 - passivation, polishing
 - other finishing: upon request
- CERTIFICATES:** - EN10204 3.1 :with each supply
 - EN 10204 3.2: upon request

Sheet. No.
IF 12

Rev.
1

Date:
March 2018

interforgia *if*

**IT IS FORBIDDEN
TO COPY, TO MODIFY
OR DISCLOSE THIS
DOCUMENT**